

RC431A

Low-Voltage Adjustable Precision Shunt Regulator

Features

- Low voltage operation to 1.24V
- 1% reference voltage tolerance
- Output voltage adjustable from V_{ref} to 6V
- Low 80 μ A operational cathode current
- 0.25 Ω typical output impedance
- TO-92 and SOT23-5 packages

Applications

- Voltage reference for discrete power circuits

Description

The RC431A is a low-voltage 3-terminal adjustable precision voltage reference regulator. It has an excellent thermal stability over the standard commercial temperature range. The output voltage can be set to any value between V_{ref} (1.24V) and 6V using two external resistors. The RC431A operates from a lower voltage (1.24V) than the traditional shunt regulator references which operate from 2.5V. When used with an optocoupler, the RC431A will be an ideal voltage reference in an isolated feedback circuit for use in switched-mode power supplies and modular DC-DC converters. The RC431A has a low output impedance of active output circuitry offering a very sharp turn-on characteristic. The RC431A will be an excellent replacement for low-voltage zener diodes in many applications such as on-board regulation and adjustable power supplies.

Symbol

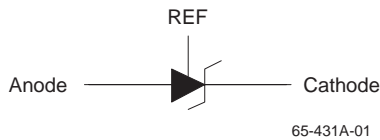

Block Diagram

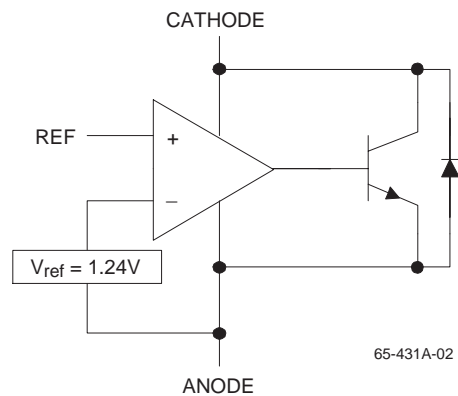

Pin Assignments

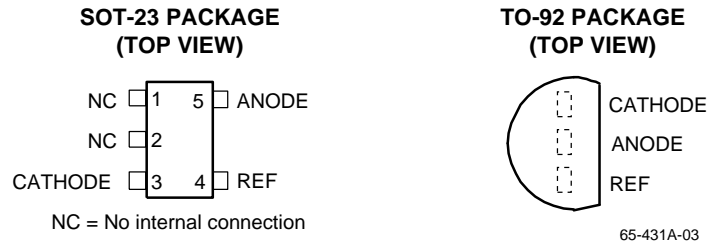

Equivalent Schematic

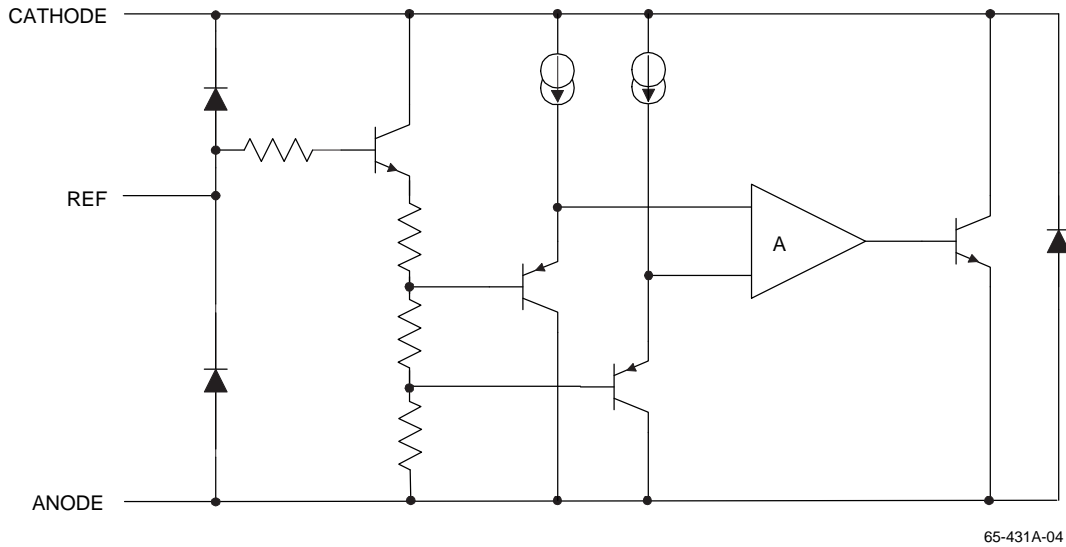

Absolute Maximum Ratings

Ratings are over full operating free-air temperature range unless otherwise noted.

Cathode voltage, V_{KA}	7V
Continuous cathode current I_K	-20mA to 20mA
Reference current, I_{ref}	-0.05mA to 3mA
Power dissipation	See Dissipation Rating Table
Storage temperature range	-65° to 150°C

Notes:

- Functional operation under these conditions is not implied. Permanent damage may occur if the device is subjected to conditions outside these ratings.

Recommended Operating Conditions

Parameter	Min.	Max.	Units
Cathode voltage, V_{KA}	V_{REF}	6	V
Cathode current, I_K	0.1	15	mA
Operating temperature range in free-air, T_A	0	70	°C

Dissipation Rating Table

Package	Power Rating T _A ≤ 25°C	Derating Factor T _A ≥ 25°C	Power Rating T _A = 70°C
TO-92	775mW	6.2mW/°C	496mW
SOT23-5	150mW	1.2mW/°C	96mW

Electrical Specifications

T_A = 25°C (unless otherwise noted), at free-air

Symbol	Parameters	Conditions	Min.	Typ.	Max.	Units
V _{ref}	Reference Voltage	V _K A = V _{ref} , T _A = 25°C	1.228	1.24	1.252	V
		I _K = 10mA, T _A = 0 to 70°C	1.221		1.259	
V _{ref} (dev)	V _{ref} deviation over full temperature range (see note 2)	V _K A = V _{ref} , I _K = 10mA, See note 2 and Figure 1.		4	12	mV
$\frac{\Delta V_{ref}}{\Delta V_{KA}}$	Ratio of V _{ref} change in cathode voltage change	I _K = 10mA, ΔV _K A = V _{ref} to 6V. See figure 2.		-1.5	-2.7	$\frac{mV}{V}$
I _{ref}	Reference terminal current	I _K = 10mA, R ₁ = 10KΩ, R ₂ = ∞ See figure 2.		0.15	0.5	μA
I _{ref} (dev)	I _{ref} deviation over full temperature range (see note 2)	I _K = 10mA, R ₁ = 10KΩ, R ₂ = ∞ See note 1 & figure 2.		0.05	0.3	μA
I _K (min)	Minimum cathode current for regulation	V _K A = V _{ref} See figure 1.		55	80	μA
I _{off}	Off-state cathode current	V _K A = 6V, V _{ref} = 0 See figure 3.		0.001	0.1	μA
Z _K A	Dynamic impedance (see note 3)	V _K A = V _{ref} , f ≤ 1KHz I _K = 0.1mA to 15mA, See figure 1.		0.25	0.4	Ω

Notes:

- Functional operation under these conditions is not implied. Permanent damage may occur if the device is subjected to conditions outside these ratings.
- Full temperature range is 0°C to 70°C.
- The deviation parameters V_{ref}(dev) and I_{ref}(dev) are defined as the differences between the maximum and minimum values obtained over the rated temperature range. The average full-range temperature coefficient of the reference input voltage, ∞V_{ref}, is defined as:

$$|\infty V_{ref}| \langle \text{ppm}/^\circ\text{C} \rangle = \frac{\{V_{ref}(\text{dev})/V_{ref}(T_A = 25^\circ\text{C})\} \times 10^6}{\Delta T_A}$$

where ΔT_A is the rated operating free-air temperature range of the device.

∞V_{ref} can be positive or negative depending on whether minimum V_{ref} or maximum V_{ref}, respectively, occurs at the lower temperature.

- The dynamic impedance is defined as: |Z_KA| = ΔV_KA / ΔI_K

When the device is operating with two external resistors (see Figure 2), the total dynamic impedance of the circuit is given by:

$$|Z_{KA}| = \frac{\Delta V}{\Delta I} \approx |Z_{KA}| \times \left(1 + \frac{R_1}{R_2}\right)$$

Parameter Measurement Information

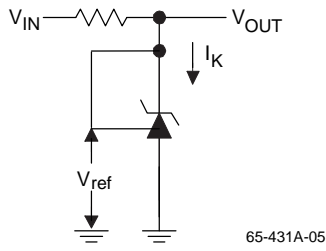

Figure 1. Test Circuit for $V_{KA} = V_{REF}$, $V_{OUT} = V_{KA} = V_{REF}$

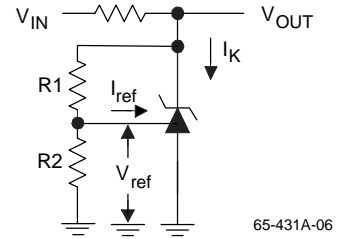

Figure 2. Test Circuit for $V_{KA} > V_{REF}$, $V_{OUT} = V_{KA} = V_{REF} \times (1 + R1/R2) + I_{REF} \times R1$

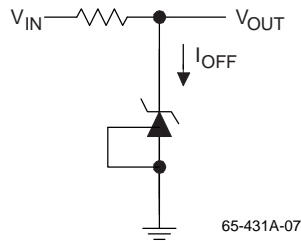

Figure 3. Test Circuit for I_{OFF}

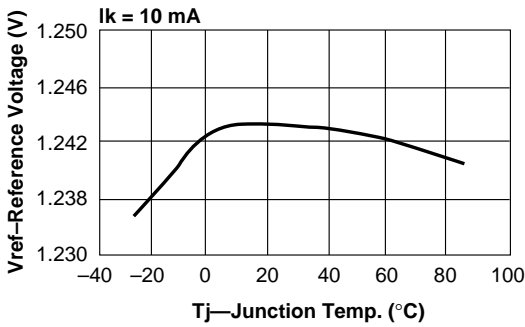

Figure 4. Reference Voltage vs. Junction Temp.

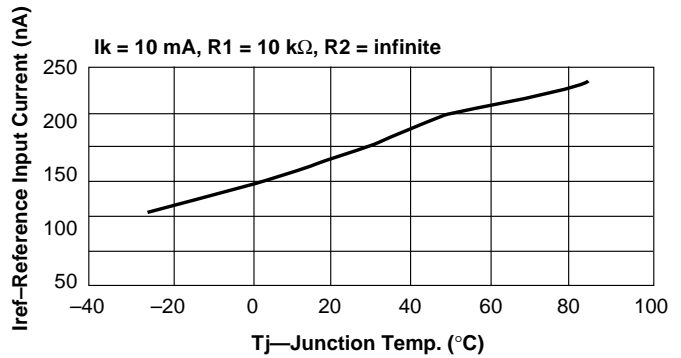

Figure 5. Reference Input Current vs. Junction Temp.

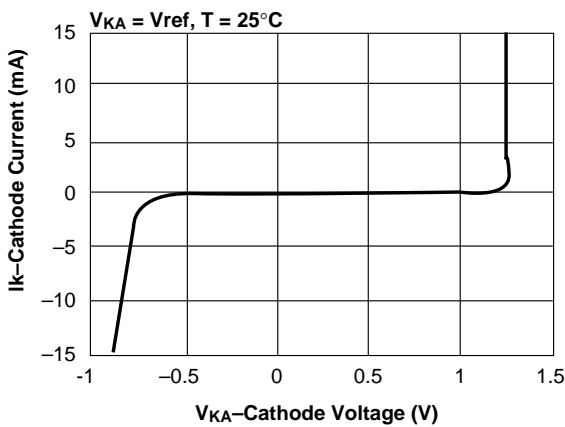

Figure 6. Cathode Current vs. Cathode Voltage

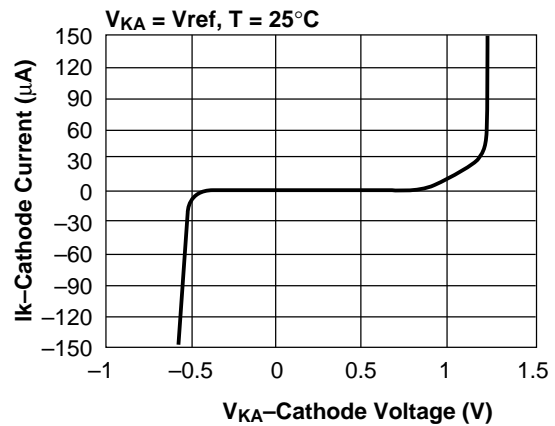

Figure 7. Cathode Current vs. Cathode Voltage

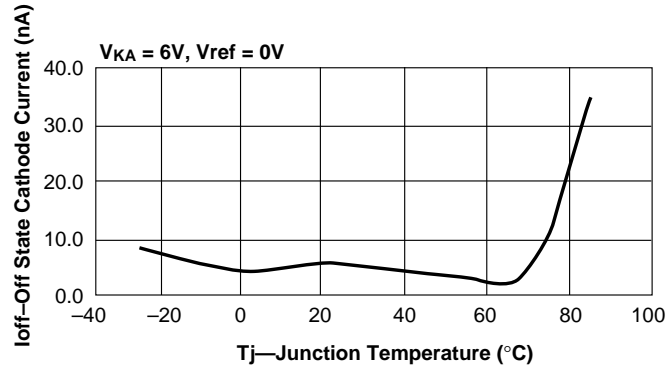

Figure 8. Off-State Cathode Current vs. Junction Temperature

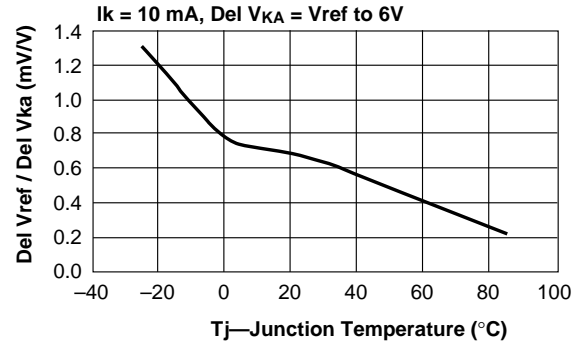

Figure 9. Ratio of Delta Reference Voltage to Delta Cathode Voltage vs. Junction Temperature

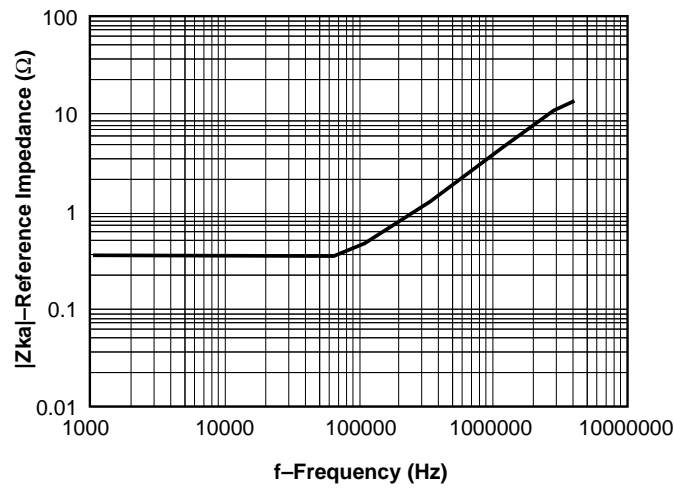

Figure 10. Reference Impedance vs. Frequency

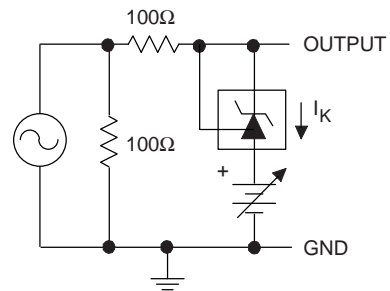

Figure 11. Test Circuit for Reference Impedance

Mechanical Dimensions

TO-92 Package

Symbol	Inches		Millimeters		Notes
	Min.	Max.	Min.	Max.	
A	.170	.210	4.32	5.33	
b	.015	.021	.38	.53	
c	.014	.020	.36	.51	
$\varnothing D$.175	.205	4.45	5.21	
E	.125	.165	3.18	4.19	
e	.095	.105	2.41	2.67	
e1	.045	.055	1.14	1.40	
L	.500	—	12.70	—	
S	.080	.115	2.03	2.92	
α	4°	6°	4°	6°	

Notes:

1. Package outline exclusive of any mold flashes dimension.
2. Package outline exclusive of burr dimension.

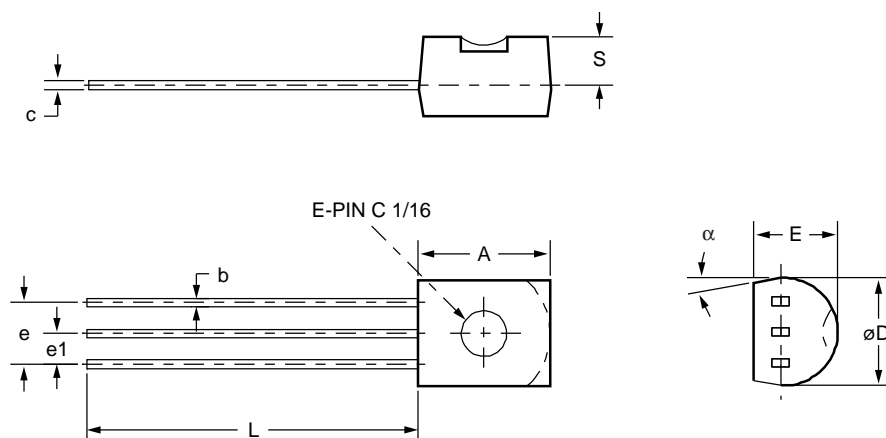

Mechanical Dimensions (continued)

SOT23-5 Package

Symbol	Inches		Millimeters		Notes
	Min.	Max.	Min.	Max.	
A	.170	.195	.90	1.45	
A1	.014	.020	.00	.15	
B	.008	.020	.20	.50	
c	.003	.010	.08	.25	
D	.106	.122	2.70	3.10	
E	.059	.071	1.50	1.80	
e	.037 BSC		.95 BSC		
e1	.075 BSC		1.90 BSC		
H	.087	.126	2.20	3.20	
L	.004	.024	.10	.60	
α	0°	10°	0°	10°	

Notes:

1. Package outline exclusive of mold flash & metal burr.
2. Package outline exclusive of solder plating.
3. EIAJ Ref Number SC-74A.

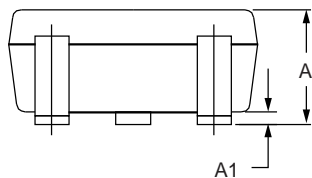
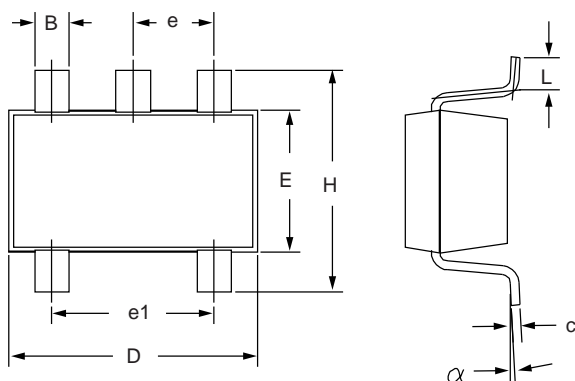

Ordering Information

Product Number	Package
RC431AM	SOT23-5
RC431AT	TO-92

The information contained in this data sheet has been carefully compiled; however, it shall not by implication or otherwise become part of the terms and conditions of any subsequent sale. Raytheon's liability shall be determined solely by its standard terms and conditions of sale. No representation as to application or use or that the circuits are either licensed or free from patent infringement is intended or implied. Raytheon reserves the right to change the circuitry and any other data at any time without notice and assumes no liability for errors.

LIFE SUPPORT POLICY:

Raytheon's products are not designed for use in life support applications, wherein a failure or malfunction of the component can reasonably be expected to result in personal injury. The user of Raytheon components in life support applications assumes all risk of such use and indemnifies Raytheon Company against all damages.

Raytheon Electronics
Semiconductor Division
350 Ellis Street
Mountain View CA 94043
415 968 9211
FAX 415 966 7742